



THE FLEXIBILITY OF BOTTOM SURFACE OR SIDEWALL PICK MOTION



MODELS:
Single Lane
Dual Lane

Dual-Lane Denester
712mm Wide Machine with
900mm Long Magazine

TRAYS TYPICALLY HANDLED:

| | |
|----------------|------------------------|
| Produce | Plastic |
| Bakery | Pressware / Paperboard |
| Confectionery | Clamshells |
| Meat / Poultry | Tubs / Bowls / Plates |

FEATURES & BENEFITS:

- Motion control method offers pick motion flexibility with the machine capable of **either denest (sidewall pick) and/or straight-line motion.**
- *Kwik Klip*™ assembly for tray holdback combined with quick and easy magazine adjustments means **greater reliability and less machine downtime.**
- Standard (IP55) construction is **suitable for most applications. Washdown (IP65) construction is available** for caustic environments.
- Air cylinder drive offers a **virtually maintenance-free** motion control and drive system.
- Clean, logical control panel design makes the machine **easy to operate.**
- Plug-and-play design translates to an **easy installation.**
- Many options available to customize and **meet your specific needs.**



TYPICAL UTILITY REQUIREMENTS:

ELECTRICAL: 110/240 VAC, 1 Ph 12 Amps Max
(with optional vacuum pump)

AIR: 80 PSI Filter and Regulator Provided

VACUUM: Up To 10 SCFM At 20" HG
(if optional pump is not purchased)

MAXIMUM SPEEDS:

- 45 Cycles Per Minute, Per Lane

OPTIONS AVAILABLE:

- Standard or Washdown Design
- Single or Dual Lane Magazine
- No Tool Magazine Changeover
- Sidewall or Bottom Surface Pick
- Kwik Klip™ Setups per Tray Size
- Actuated Clip Assemblies
- Vacuum Pump or Venturi Vacuum System
- Various Cycle Control Alternatives
- Missed Detection System
- Low-Level Magazine Alarm
- Stack Light
- Floor Stand
- Screw Height Adjustment
- Casters

PRODUCT SIZE RANGE:

- Minimum: 110mm x 60mm
- Maximum: 712mm x 350mm x 150mm deep

The maximum product size is determined by the magazine centers.

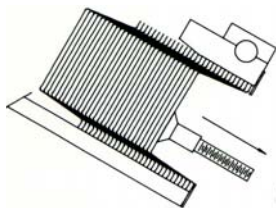
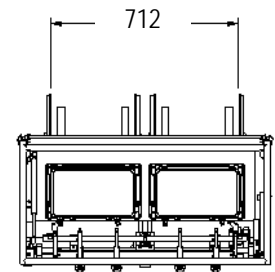
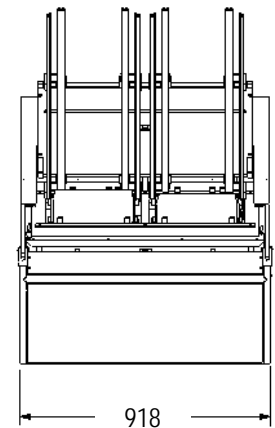
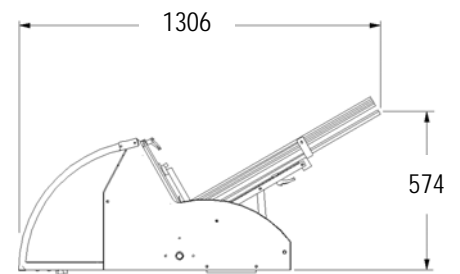
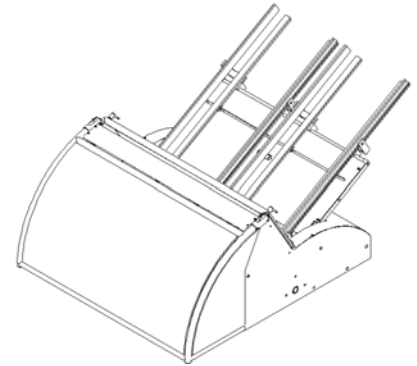

STANDARD PICK
STANDARD MOTION: Smooth, rigid bottom tray.

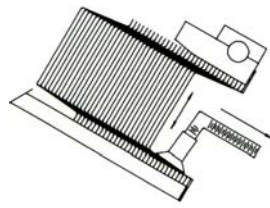

DENEST MOTION
DENEST MOTION: Smooth, rigid sidewall tray (bottom not smooth).

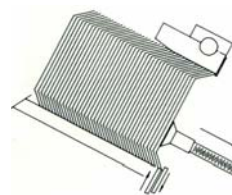

CLAMP & RELEASE
THICK, RIGID TRAY: Clamp and Release. Retractable front clip and clamp device for the second tray.