



**CLOCKWISE
or
COUNTER-CLOCKWISE
ROTATION**



MODELS:
VBF-27
VBF-30
VBF-36

Counterclockwise
Model 27" ID

FEATURES & BENEFITS:

- Simple design translates to an **easy installation**.
- 11 gauge stainless steel construction provides a **rugged and durable machine**.
- Custom tooling for your specific part yields a **reliable and efficient operation**.
- Simple controller makes the machine **easy to operate**.
- Heavy-duty base drive offers a **virtually maintenance free operation**.
- Quick and easy product changeover means **less downtime and greater machine efficiency**.
- Many options available, **allowing the end user to customize the feeder to their specific needs**.



BOWL DIMENSIONS

MODEL	A	B	C	D*
27 in ID	27 in	29.50 in	11.375 in	12 in
30 in ID	30 in	32.50 in	11.375 in	16 in
36 in ID	36 in	38.50 in	11.375 in	20 in

*Actual Bowl Height Depends on Part Size

TYPICAL POWER REQUIREMENTS:

ELECTRICAL: 110 VAC 15 Amps Max

AIR: 80 PSI (when required)

SPEED RANGE:

- 5 to 100 Parts Per Minute (depending upon the application)

OPTIONS AVAILABLE:

- Clockwise or Counterclockwise Rotation
- Multiple Discharge Lanes
- Multiple Part Tooling
- Quick Dump Windows
- Vibratory Inline Tracks
- Gravity Tracks
- Conveyors
- Base Plates
- Table Frames
- Vibratory Storage Hoppers
- Elevating Storage Hoppers
- Bowl Coatings
- High Level Shutoff
- Sound Enclosures
- FDA Pharmaceutical Construction
- Tab Mounts
- Escapements, Shuttles Pick and Place

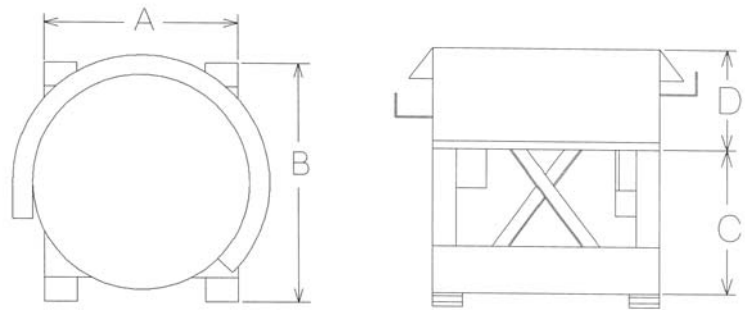

TYPICAL FEED SYSTEM

